

LOC	DIST	P	F	ZONE	LTR	DESCRIPTION	DATE	APPD
BD	35				G	REDRAWN W/O CHANGE PER EC 0020-774-94	09/04/94	AF
					H	OBS -2 PER EC 0020-0136-95	17 JUL 95	AF

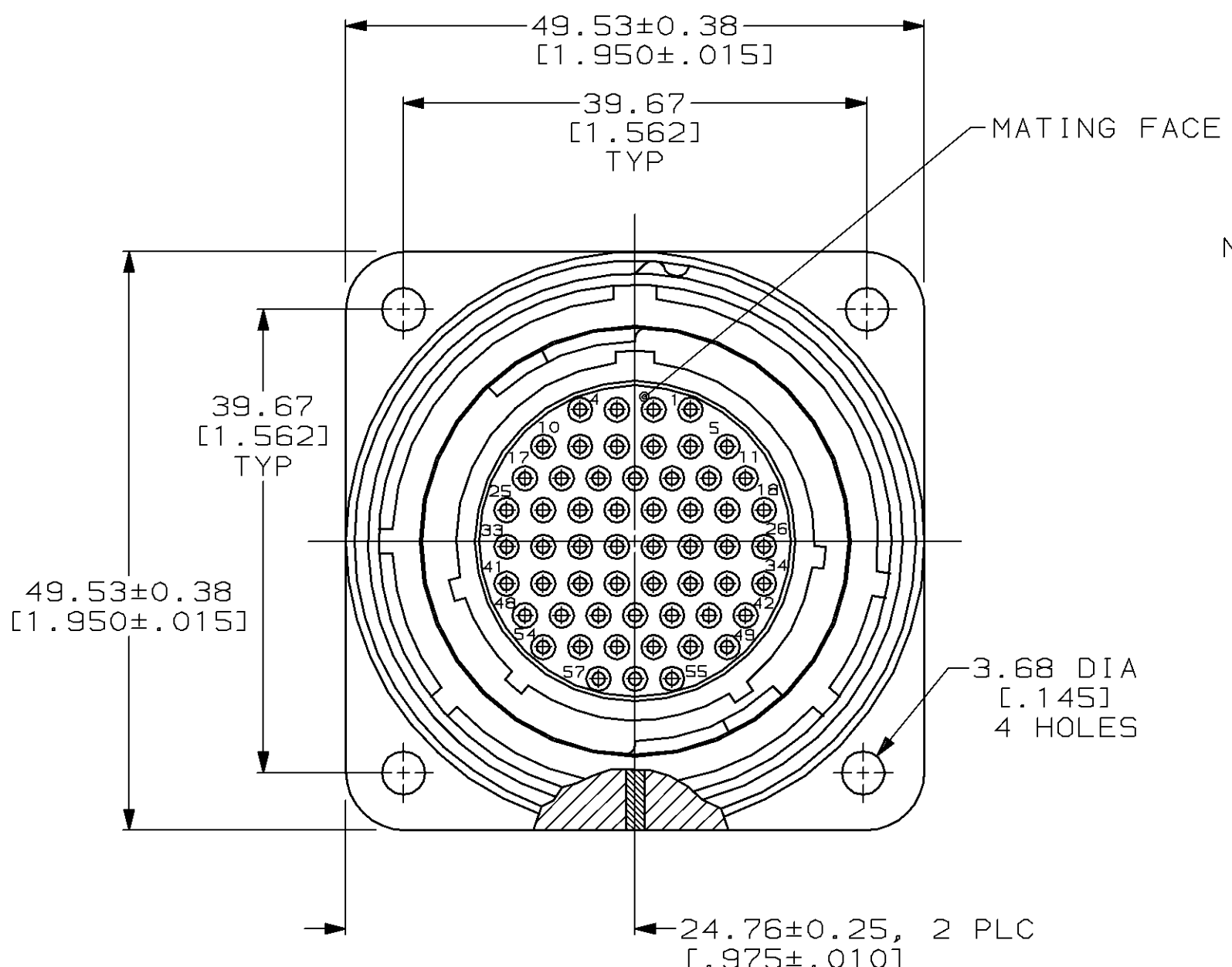

METAL SHELL RECEPTACLE MATERIAL: ZINC ALLOY FINISH: NICKEL PLATED PER QQ-N-290  
 RECEPTACLE, REV SEX ARRANGEMENT 23-57 MATERIAL: THERMOPLASTIC COLOR: BLACK  
 GROOVED PIN, 2 PLC MATERIAL: STEEL ALLOY FINISH: NICKEL PLATED PER QQ-N-290

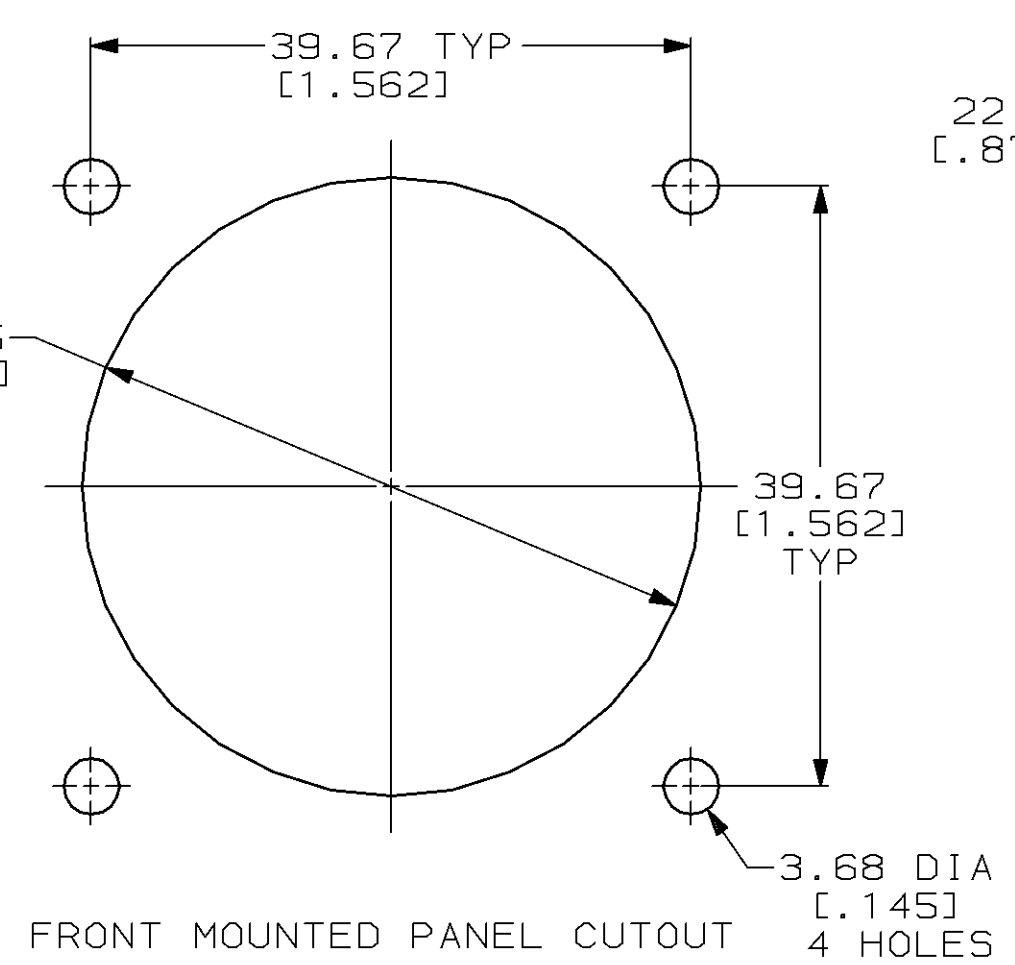
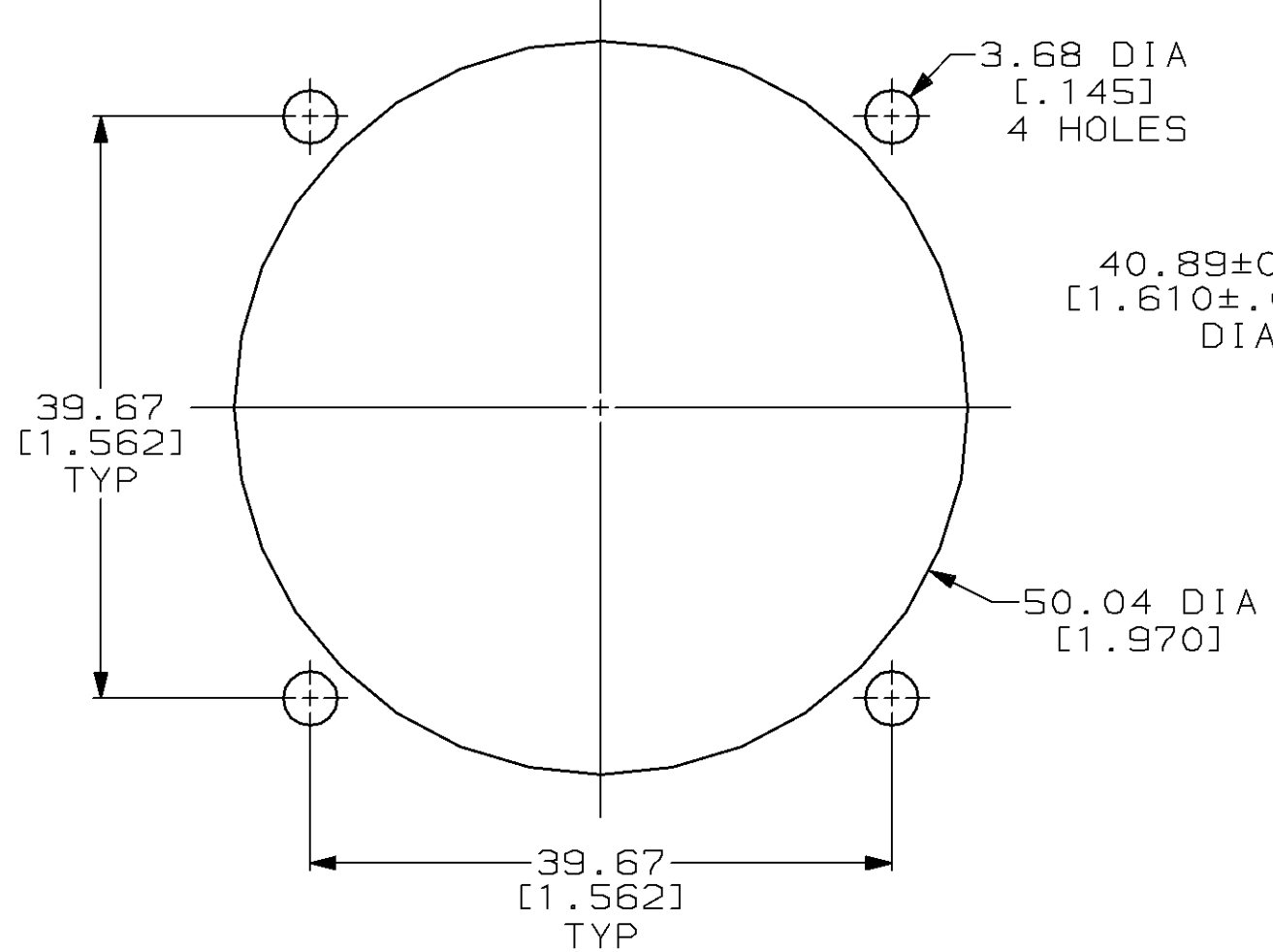
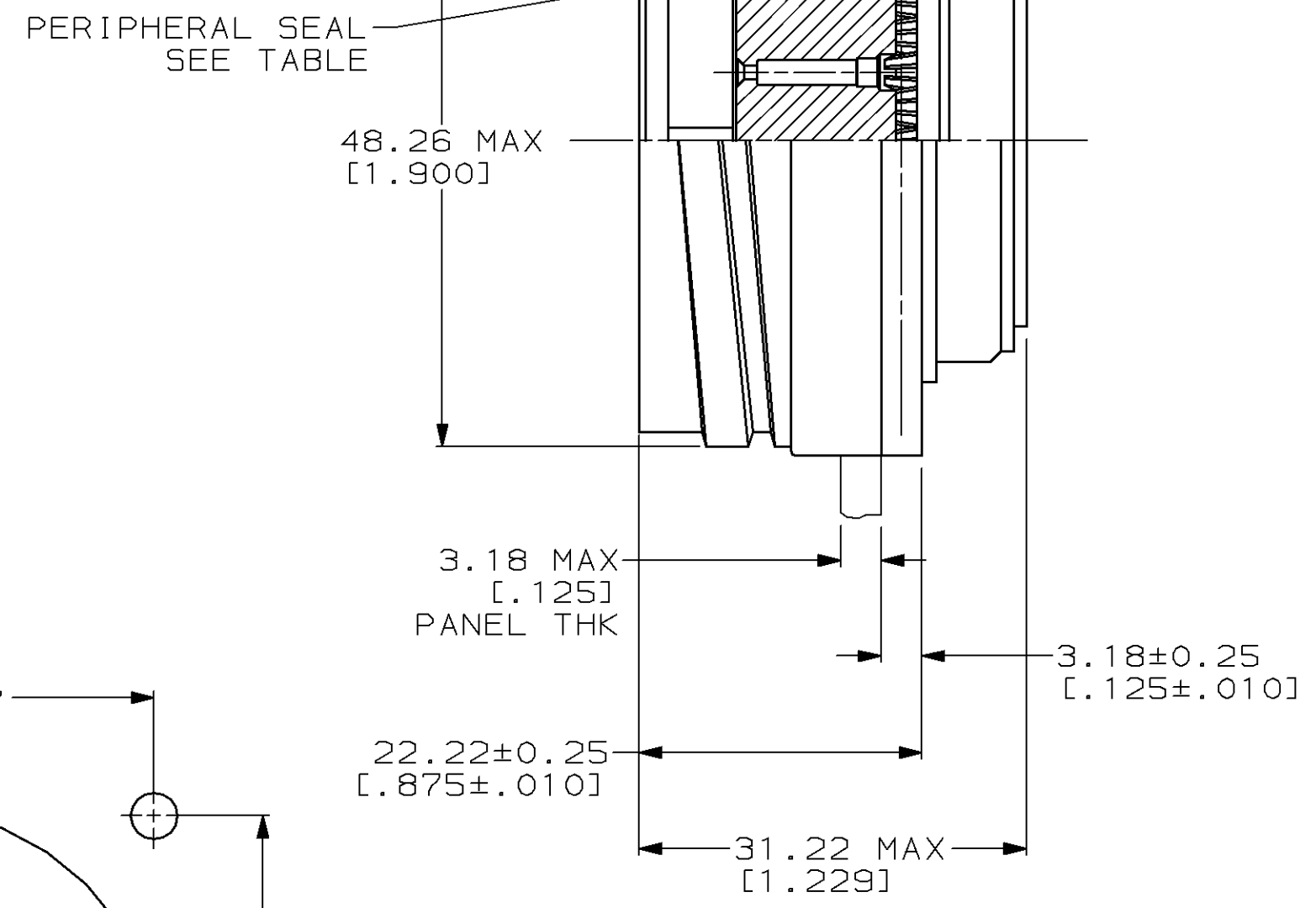

OBSOLETE	YES	208475-2
	NO	208475-1
PERIPHERAL SEAL	PART NUMBER	

- RECEPTACLE MATES WITH AMP PLUG 208474-1.
- AMP PART NUMBER AND DATE CODE TO BE LOCATED ON EDGE OF FLANGE.

DO NOT SCALE PRINT. UNLESS SPECIFIED DIMENSIONS IN mm [INCHES] TOLERANCES ON: 2 PLC DEC ±0.13 [.005] 3 PLC DEC ± - ANGLES ± -	DR 09-04-94 D.HARDY	<b>AMP</b> AMP Incorporated Harrisburg, PA 17105-3608	
	CHK 09-07-94 R.STONE		
MATERIAL SEE CALL OUT	APPD 09-30-94 A.FRANTUM	NAME RECEPTACLE ASSEMBLY, 28-57, REVERSE SEX, CMC	
	APPD 09-30-94 A.FRANTUM	SIZE C	CAGE CODE 00779
FINISH SEE CALL OUT	APPLICATION SPEC -	DRAWING NO C=208475	
	WEIGHT -	SCALE 2:1	SHEET 1 OF 1

THIS DRAWING IS A CONTROLLED DOCUMENT FOR AMP INCORPORATED. IT IS SUBJECT TO CHANGE AND THE CONTROLLING ENGINEERING ORGANIZATION SHOULD BE CONTACTED FOR THE LATEST REVISION.